

KORETECK®

PANELIZED BUILDING SYSTEM

INTRODUCTION

This guide is furnished as a supplement to panel installation drawings.

Note: Variations from the contents of the manual can occur because of specific customer requirements and subsequent engineering changes. Always refer to the panel installation drawings supplied that will govern specific part and assembly arrangements and applicable installation details.



TABLE OF CONTENTS

	<u>Page</u>
Safety Guidelines	3
Handling Panels	3
Unloading and storage	3
Handling Material	4
Hardware, fasteners and Foam storage	4
Tools and Related Materials	4
Fasteners	4
Description	4
Panel Fasteners & Tools	4
Shiplap Fasteners	4
Panel-to-Structural Fasteners	5
Wall System General Information	6
Wall panel dimensions	6
Panel Installation	7
Track Installation	7
Erection Procedure	8-9
Track Connection	10
Girt Connection	11
Installation of Panels on Multiple Levels (Stack Joint)	12
Eave Connection	13
Window & Door Installation	14
Field Cut	14
Pre- Designed	14
Field-Cut Door Installation Guide	15
Field-Cut Window Installation Guide	16
Sealing & Damp proofing	17
Wiring & Plumbing	17
Finishing	17
Exterior	17
Interior	17
General Information	18
Appendix	19
Support	20

SAFETY GUIDELINES

Safety

Safety must be a prime concern throughout the entire erection process. This manual contains safety information that is important for all workers to know and understand. It is not possible to present complete and comprehensive safety instructions in this manual. All local, state and O.S.H.A. safety regulations must be followed at all times. The erection contractor has the ultimate responsibility for the safety of workers and must comply with all applicable safety regulations.

The Occupational Safety and Health Act regulations applicable to the erection of this or any other building are identified as Part 1926, Safety and Health Regulations for Construction and are available from any government book store and online. These O.S.H.A. Regulations should be recognized as a job site requirement and must be fully complied with. Failure to do so may result in worker death or injury as well as substantial fines in the event of an O.S.H.A. inspection.

Recognize Safety Information

This is the safety-alert symbol. When you see this symbol in this manual, be alert to the potential for personal injury. Follow recommended precautions and safe practices.



Welding should not be done close to the panels without proper protection.

Follow Safety Instructions and Warnings

Carefully read and follow all safety and warning messages in this manual and all applicable erection drawings.

HANDLING PANELS

Unloading and Storage

Your material is carefully inspected, loaded and accepted by the transport company before leaving the manufacturing plant. It is the carrier's responsibility to deliver the shipment damage free.

It is the consignee's responsibility to inspect the shipment for loss, damage and shortages when it is delivered. Instructions for material inspection and handling are supplied with the consignment.

When loading or unloading panels from a truck, make sure that the panels are stacked in a flat horizontal plane with no more than fifteen panels per stack and placed on top of level pads to avoid damage by forklifts. The Expanded Polystyrene (EPS) pads minimum 42 inches long & 12 inches wide should be maximum spacing of 4-foot intervals. A load distribution device such as a pallet or sheet of plywood is required to avoid damage to the panels. Do not allow panels to rest directly on the ground.

When installing the panels, handle the panels by the exposed metal stud at the top and bottom to avoid damage to the polystyrene insulation. **Do not use the side shiplaps to lift the panels** as this can cause the internal EPS bond to break causing localized delaminating of the panels.

When unloading and storing at the job site, always place dunnage under the panel stacks and cover.



CAUTION: Always wear gloves when handling panels.

WARNING: Carrying a wall panels in windy conditions is extremely hazardous. Panels may act like a sail throwing you off balance and causing you to fall. Keep loose panels secured to prevent wind damage.

HANDLING PANELS

Hardware, Fasteners and Foam Storage

All building materials used for the wall installation should be checked, separated, and stored in a dry protected area so that they are not damaged, stolen, or lost.

Each KORETECK panel is marked with a unique panel number on the bottom stud for a specific location. Be sure to place materials so they are near the area of intended use to eliminate unnecessary handling. Always ensure that the tag on the bottom of the panel is placed down in base track during installation.

TOOLS AND RELATED MATERIALS

Before starting panel installation, be sure that proper tools, in good repair, are on hand. An inefficient drill motor, lack of tools, inadequate power source or other equipment deficiencies slows down the entire crew. The cost of lost time can easily become greater than the cost of providing adequate, well-maintained equipment.

Erection procedures shown in this manual will require the following tools and materials:

- Adjustable Clutch Electric screw gun with 3/8" hex sockets and a 6" or 8" extension.
(2 extensions are provided from Koreteck with your order)
- Self-drilling fasteners (#14 x 3/4") supplied with your order.
- Self-drilling fasteners (off-set girt fastener) (2-1/2" or 3-1/2") supplied with your order.
- Powder activated nail gun or hammer drill (for base track installation)
- 4' level
- Chop Saw
- Reciprocating saw
- Steel tape measure
- Chalk line
- Gloves
- Hot Rod foam cutter – Demand Products at www.demandproducts.com
- Appropriate safety equipment and materials

FASTENERS

Description

The shipping manifest will list the supplied wall fasteners. The required location is shown on the wall panel layout drawing details. The shipping manifest accompanying the panels is used to determine the actual fasteners furnished.

Shiplap Fasteners

Type: **Self-drilling fasteners (#14 x 3/4") Supplied with the order.**

Required tool: Adjustable Clutch Electric screw gun with appropriate hex head drive and extension

Note: Use depth locating or torque control electric screw gun for driving self-drilling screws. High RPM (2000-2500 RPM) drivers are necessary to attain optimum speeds. High tool amperage (4 to 7 amps) is required to achieve the proper torque for secure fastening.

Panel-to-Structural

Type: **Self-drilling screw or offset screw (#12-14 2-1/2" or 3-1/2") supplied with your order.**
Required tool: Adjustable clutch electric screw gun with appropriate hex head drive and extension

Note: Use depth locating or torque control electric screw gun for driving self-drilling screws. High RPM (2000-2500 RPM) drivers are necessary to attain optimum speeds. High tool amperage (4 to 7 amps) is required to achieve the proper torque for secure fastening.

Do not overdrive fasteners!

Use drivers with torque control set to function properly for the combination of fastener size and material thickness.

WALL SYSTEM GENERAL INFORMATION

The KORETECK® T Panel

The 4' KORETECK® T panel is the standard building block of the system. The T panel has a shiplap on each side of the panel. The orientation of these panels is alternated to mate the metal of the shiplaps together, enabling a positive steel-to-steel connection. The panels are stitched together using No.14 x 3/4 inch self-drilling screws at 2-foot on center. Local conditions may require the structural engineer to ask for tighter screw spacing. Custom width panels are often required in each project. These panels are made to specific widths that are less than the standard 4' wide panel, but no more narrow than 2'-0". The panels are specifically marked and must be installed in the designated location marked on the drawings.

Panels Designed for Gable Ends

In order to use the panels in gable end applications KORETECK® produces two types of special panels. These panels are detailed on the fabrication list supplied to the customer during the ordering process. The types are **Left** and **Right Cut**. These panels are standard T Panels with a gable cut. A **Left Cut** panel when the shiplaps are orientated facing the front the gable slope is running right to left (left being the shorter length). With a **Right Cut** the slope runs left to right.

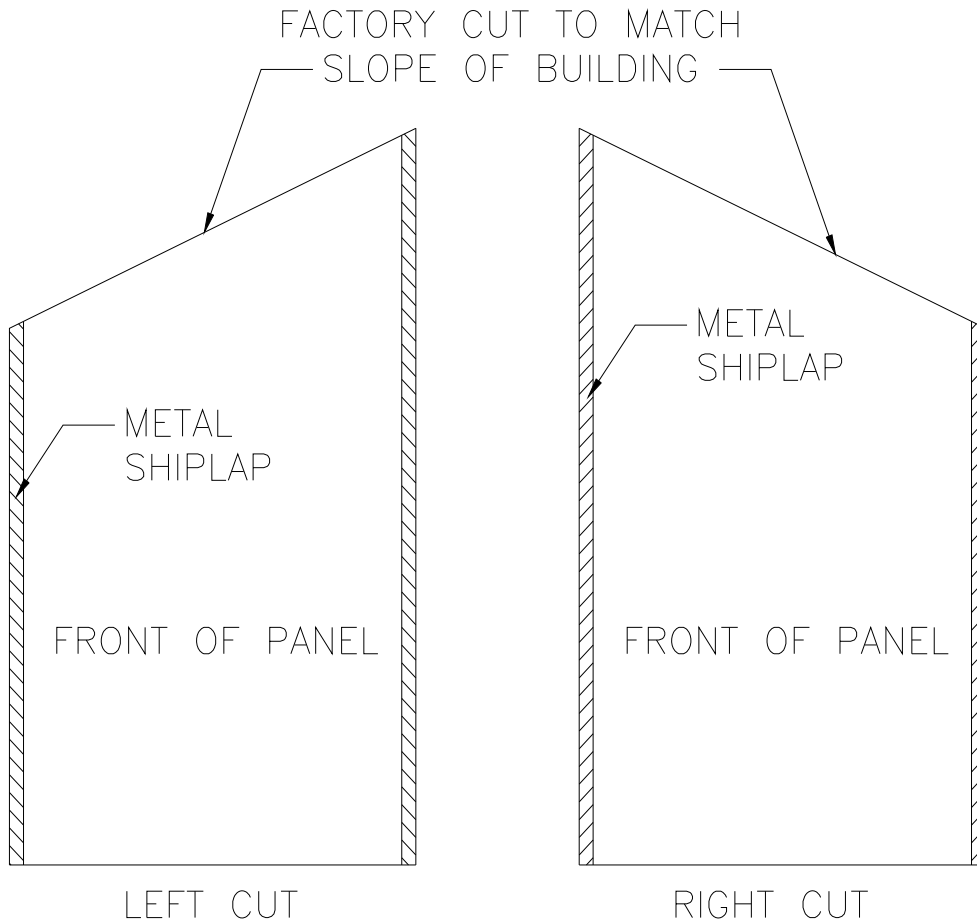

PANEL INSTALLATION

Track Installation

The method of installation is largely dependent on the specific engineering affecting the design of the project. However, the general steps outlined below are applicable in most situations. It is critical to ensure the footing for the track is as level as possible for proper installation of the panels. The panel design does however allow some field adjustment.

Install the 18 gauge galvanized steel base track (**color-coded yellow**) prescribed by the project's engineering specification. The track is secured using fasteners as specified by the engineer of record for the project. **(Fasteners for base track to foundation attachment not provided by KORETECK)** Continuous beads of water resistant sealant **(Sealant not provided by KORETECK)** are recommended between the concrete and the track



Warning:

Always wear protective clothing and eye and ear protectors when using powder actuated nailing or other fastening systems.

Identification of specific requirements for installation is beyond the intent of this procedure. The objective of the OSHA Standards is to protect the worker from injury or illness. In so doing, past installation methods may not comply with current requirements.

Safe installation practices may be further defined and made mandatory by state or local ordinances.

Maintenance of good housekeeping on the jobsite is recognized as being most important to both OSHA compliance and to the successful job completion.

Installation Procedure

After the track is installed, **Builder's Check Dimensions** must be marked on the inside center of the track to help assure proper spacing of the panels. These dimensions are shown on the Installation drawings and correspond to the centerline of the panel's shiplap joint.

Installation usually starts at the corner of the building. There are four standard corner orientations (See below). It is critical to use the corner orientation called for in details (clouded detail) on the installation drawings.

Install the short leg of the corner connector angle to the shiplap of one of the panels while lying on flat surface and then tilt it into place. Once in position check for true and plumb. Secure the panel to the base track. The adjacent corner panel is then tilted into the base track and slid into position. The panel is checked for plumb and secured to the corner angle and then to the track. **(Hint: Always fasten all panels to base track from the outside)**

To avoid surface irregularities and to compensate for possible minor variances of the structural steel components, the KORETECK panel is wrapped onto the structural steel. To do this properly the screw sequence shown in the drawing on the next page is critical. Most post installation surface irregularities are due to improper screw sequences. The standard 4' panels have a mark at the edge of the panel on two-foot centers to help locate screw locations without having to measure 2' centers. **See drawing.**

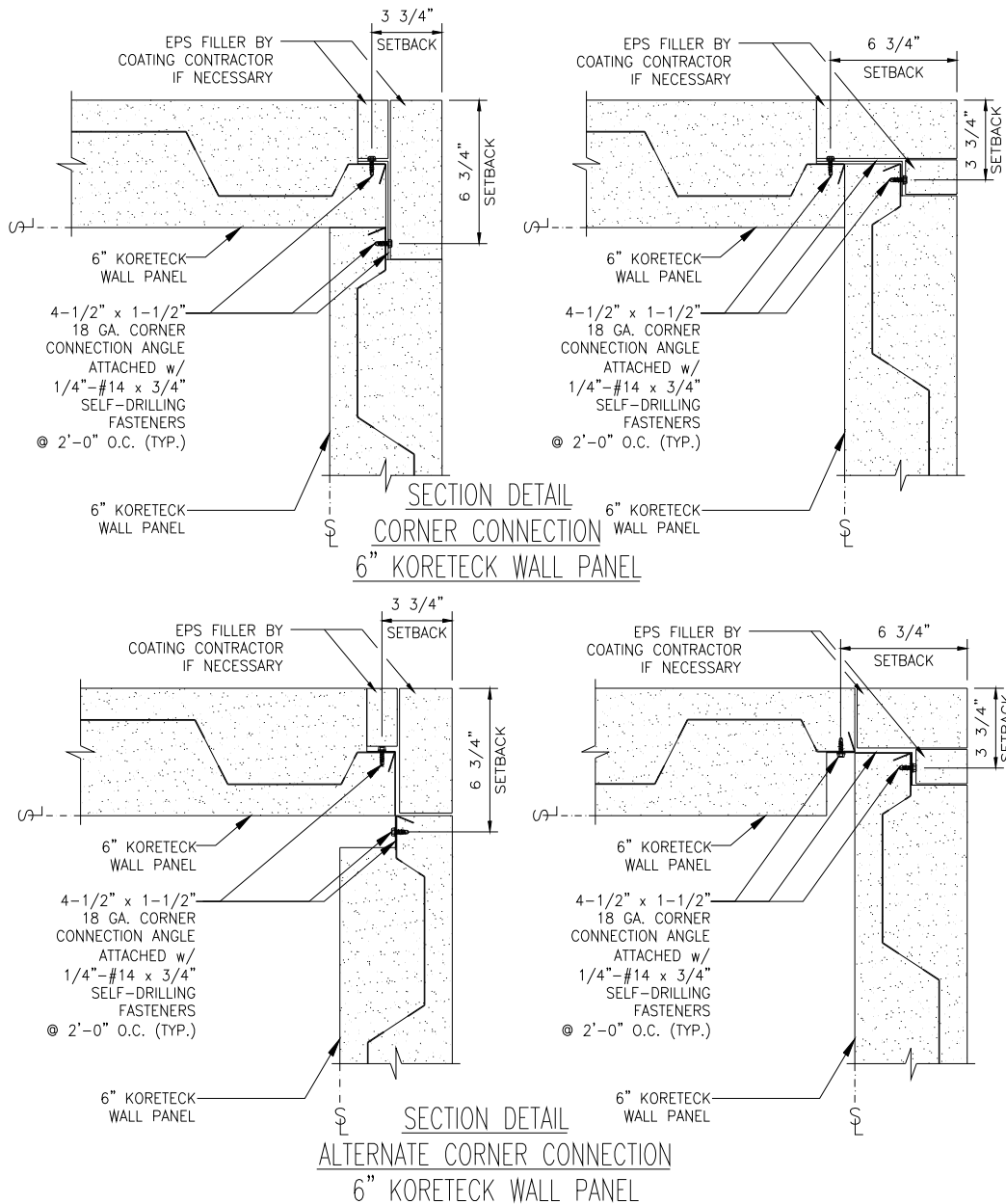

Install the next wall panel in from the corner by sliding it into place, check the panel for level and spacing and then stitch panel-to-panel connection together beginning at bottom of the panels and work towards the top. Never start in the middle as this will likely result in a shiplap screw not making a solid connection with the opposite panel's shiplap. Do not make a connection to the base track until the next panel is set in place and connected from bottom to top of the shiplap. This allows the panels to be slid into place without fighting the track connection. If there is a misalignment of the panel face it is usually due to the shiplap screw not being properly installed and blocking the panel joints from properly aligning. Once attached at the shiplap, Panel-to-structural fasteners at base track, girts(s) and eave strut may be completed, in that order, on corner panel. This will eliminate any misalignment of the surface from one panel to the next. Always start at the end of the panel and work in direction of sheeting. Do not fasten the second panel to the structure until third panel is stood and fasten to shiplap of second panel.

Note: If the screw fails to successfully connect the panels together, remove the screw before installing any additional fasteners. Failure to do so will lead to misalignment of the panels.

Note:

If the KORETECK® panels are used as self-supporting load bearing panels assure adequate temporary bracing to avoid wind damage and to make sure the walls are plumb

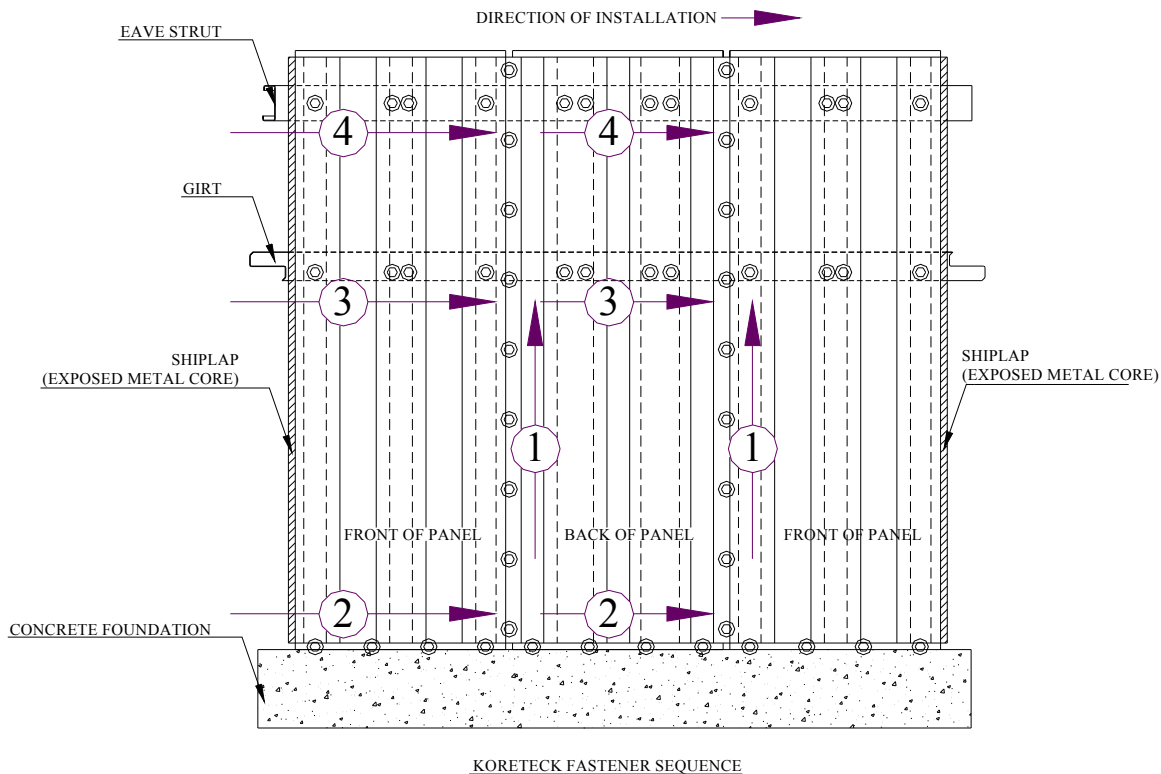

KORETECK FASTENER SEQUENCE

Track Connection

Attach the bottom of the first panel installed to the base track by installing the self-drilling screws on the outside of the building at a maximum spacing of 1'-0" on center. All screw sizes and screw patterns require verification by the project engineer to meet local conditions. This step must be done at least one panel behind the panel being installed.

Always attach the panels to the track from the outside. The track is oversized relative to the panel's bottom stud allowing the panels to slide easily in the base track for installation. If the connection is made from alternating sides the resulting wall will not stay in plane.

When used in load bearing situations or on walls with parapets, a top track similar to the base track is attached to the top of the panels using the same recommended screw size and spacing for the project.

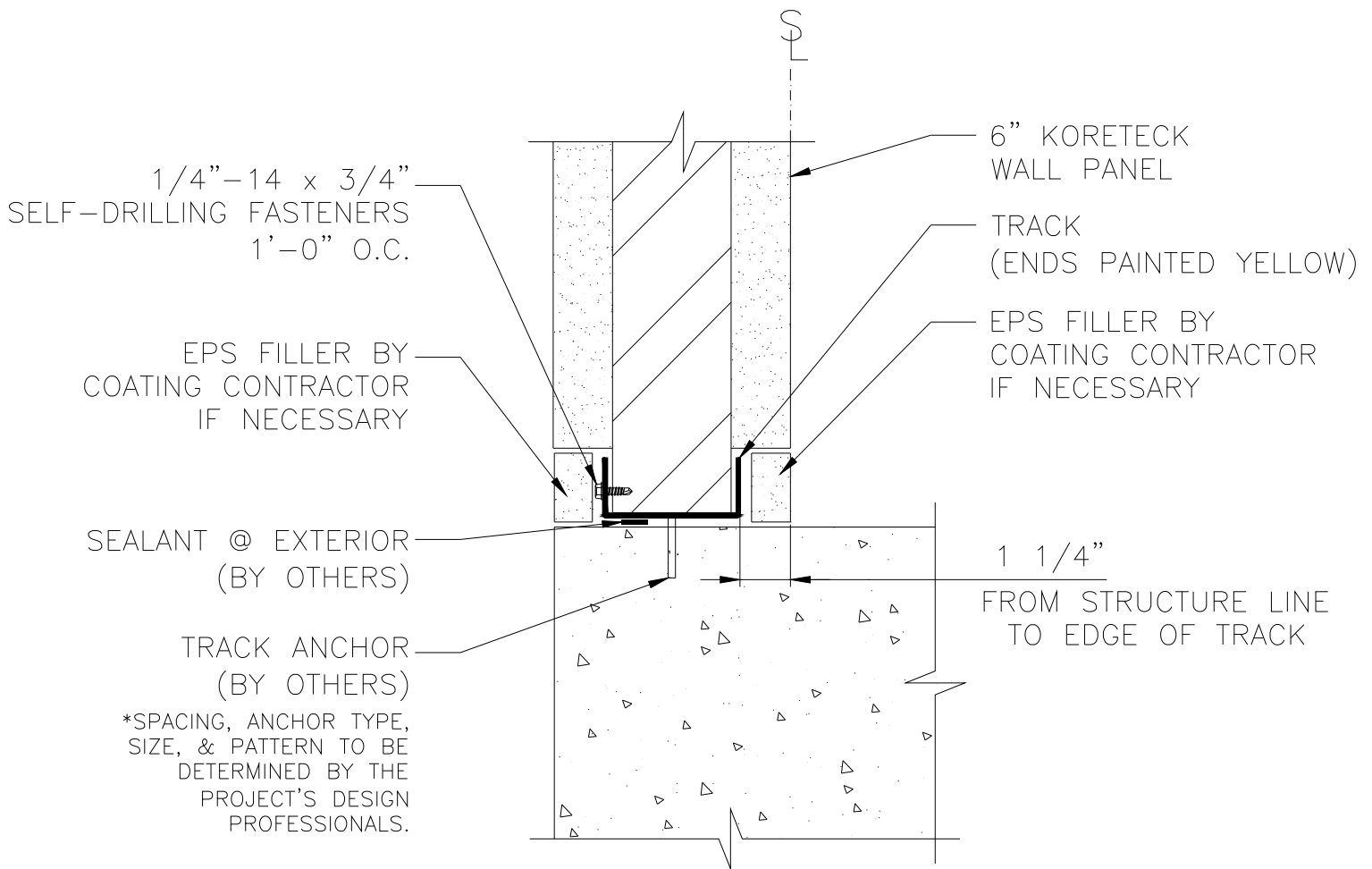

TYPICAL BASE DETAIL

Girt Connection

The **KORETECK®** Panels, using the supplied offset fasteners, are attached to all girts or supplied structural members with a minimum of 4 fasteners in each 4-foot wide panel section.

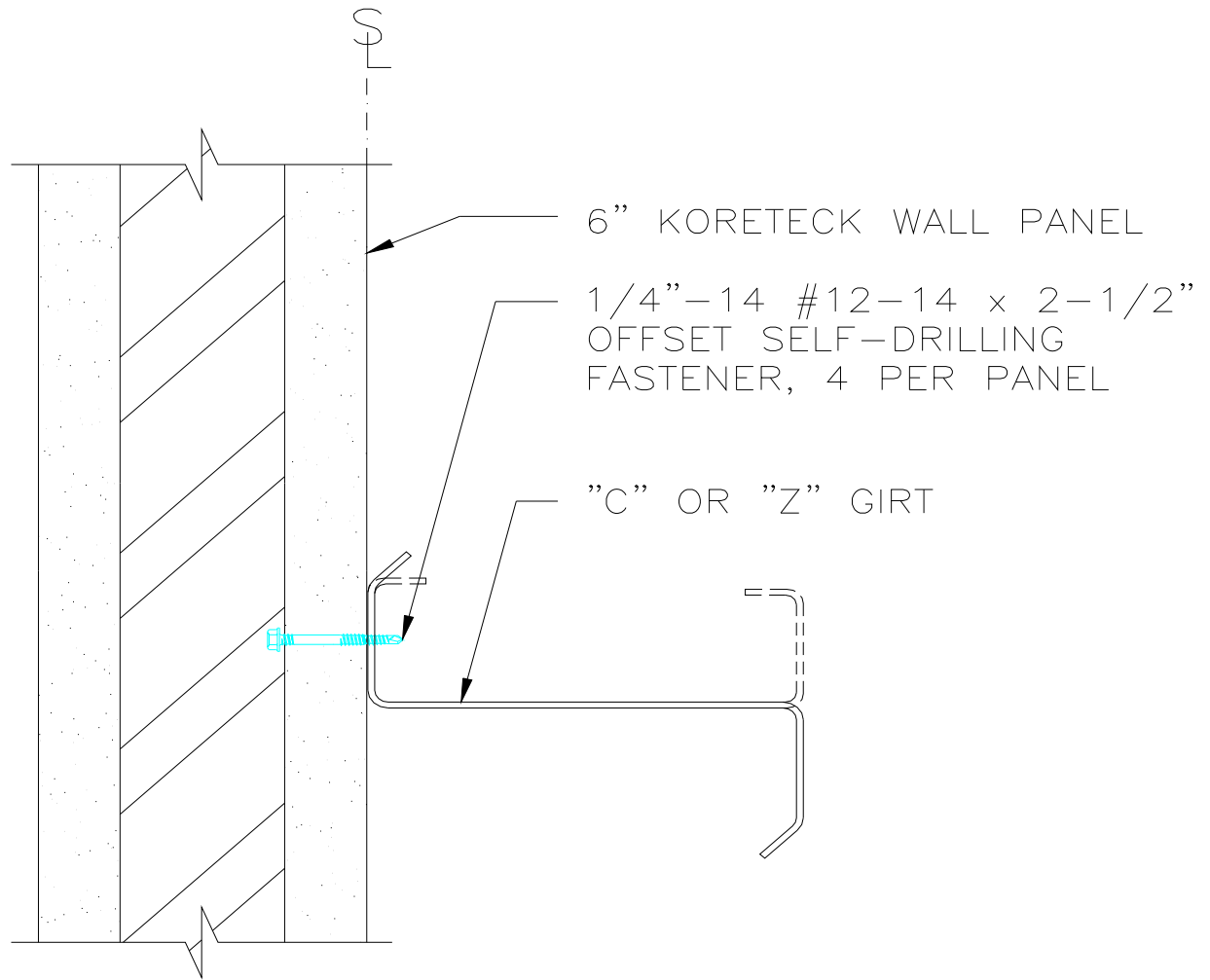

GIRT DETAIL

In order to locate the optimum positions for the screw installation follow the simple instructions below.

- a) Mark the front of the panel with a chalk line centered on the mid point of the girt face and the chalk line on the previous panel.
- b) Locate the locator ridges on the face of the panel.
 - a. Solid lines indicate the fastener locations for attaching drywall or siding to the panels
 - b. Dashed or broken lines indicate the fastener locations for attaching the panel to the building structure (Girts, eave struts)
- c) Using a screw-gun with an appropriate hex head extension push the screw through the foam until it locates the

steel core. Once core is located, start the screw-gun turning to drive the screw through the panel and into the girt. Make sure that the clutch setting on the gun is set to stop when the offset screw is seated in the girt.

Installation of Panels on Multiple Levels (Stack Joint)

Where walls are greater than 18 feet high the **KORETECK®** panels can be stacked using the factory supplied 'H' 18 gage track (field angle), as shown below. The following installation sequence is recommended.

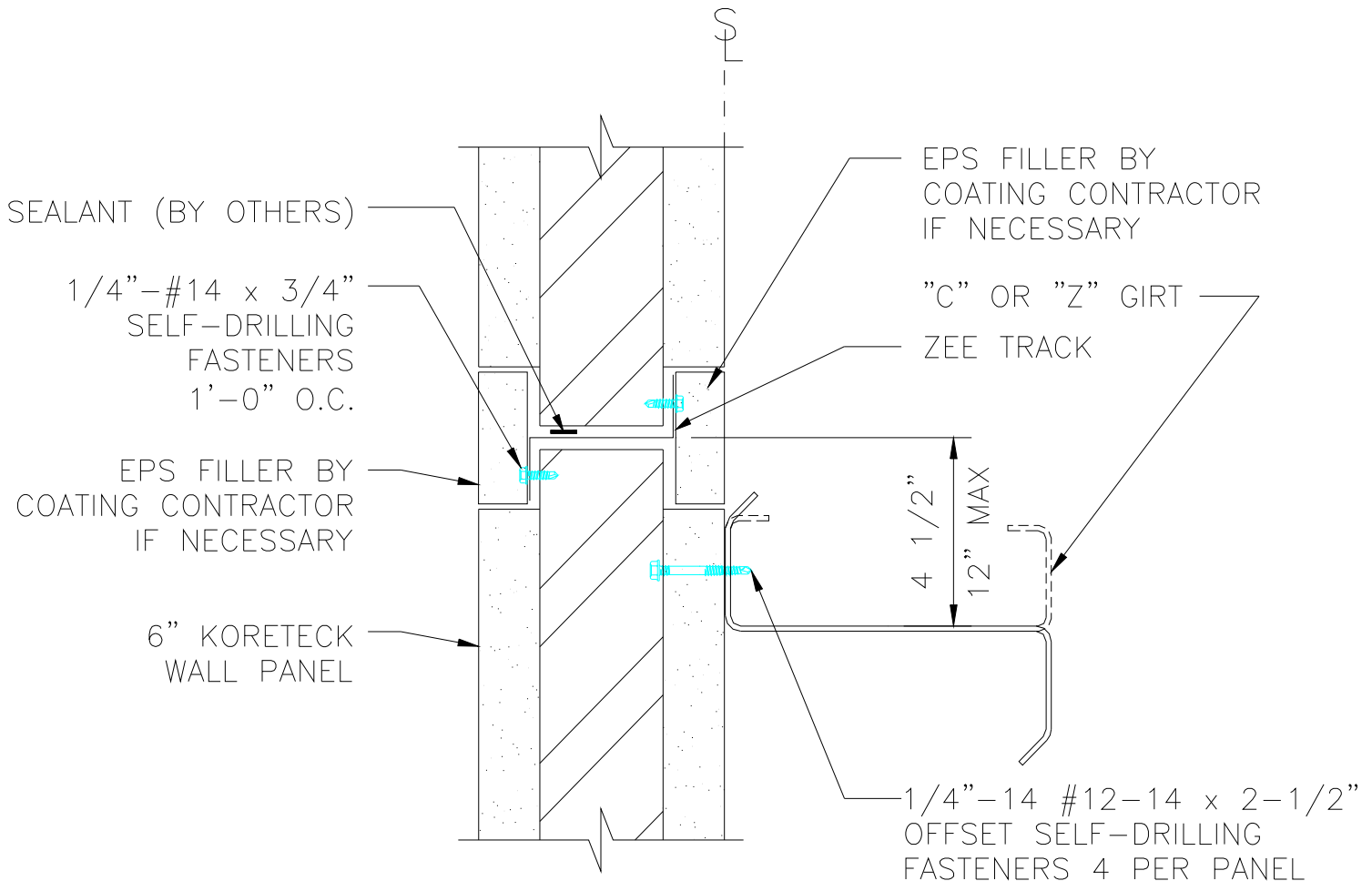

- The lower panels are installed and attached to the girt as described previously.
- The 'Z' track (supplied in 12 foot lengths) is attached to the top of the lower panel using No 14 x 3/4 hex head screws at 1 foot on center. [Sealant can be applied if required].
- The upper panel is lifted into position and secured at the eave strut using the supplied offset fasteners (using the same spacing as a normal girt connection), and to the 'Z' track from the inside of the building.



Warning:

During the installation of the upper panel make sure that suitable and adequate precautions are taken for the weight, size and prevailing wind conditions.

Eave Connections

Below are examples of typical panel connections and roof-trim details.

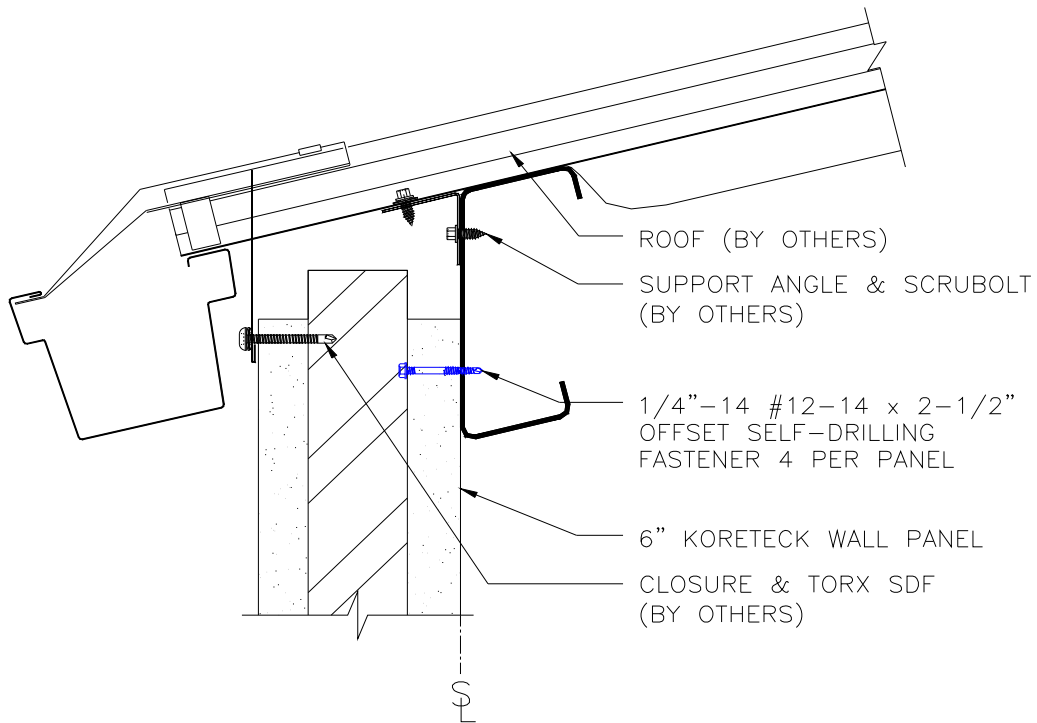

TYPICAL EAVE DETAIL

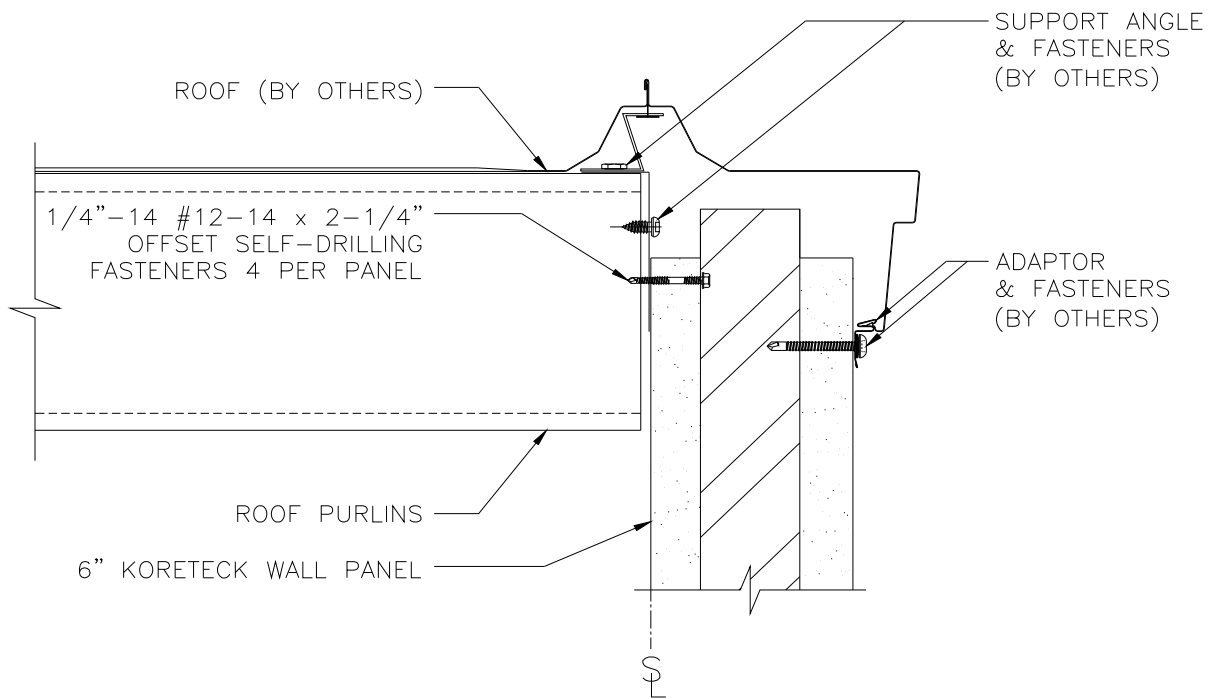

TYPICAL GABLE DETAIL

Door and Window Installation

Field Cut Door and Window Openings

When used in conjunction with Butler® framed buildings it is recommended that the window and single leaf man door openings be cut out after the panels are in place. This speeds up erection time and allows for field adjustment should it be required.

The recommended method for field cutting is outlined below.

- a) Mark the rough opening size on the inside and outside of the panel surface using a marking pen.
- b) Using a “Hot-Knife” cutting tool cut a seven-inch wide by 1.5” deep slot whose centerline corresponds with the desired rough opening. This will expose the panel’s high rib on both sides
- c) Use a reciprocating saw to cut the steel core.
- d) Properly dispose of the KORETECK (foam and steel) removed. Be careful of the sharp edges.
- e) At each corner of the window/door insert the supplied 3-1/2 inch (90°) corner insert. See Drawings
- f) Frame the opening with the ‘C’ track supplied, square up the frame and secure using No.14 x ¾ hex head self-drilling screws.

Pre-designed Door and Window Openings

Where the panels are used for free standing buildings (or where requested by the customer on framed buildings) special panels are made to accommodate door and window openings. Because of the panel design, the rough openings are based on the 4 foot and 2 foot module sizes. A typical rough opening for a single panel (4 foot) is 3’10½” in width with no restrictions on height. Similarly a 2-foot module will provide an opening of 1’10½”. For door and window openings larger than 4 feet multiples of the above 2 and 4-foot modules can be used.

Note: Freestanding/ load bearing buildings will require a local engineer to approve the panel design. Based on local conditions the engineer may require the addition of headers and/or structural support.

Panel sizes and locations are detailed on the erection drawings supplied. The increased detailing required and the number of specialized panels required to fit the door and windows into the architectural plans increases the cost per square foot of the building.

Details for weather proofing and finishing the door and window openings are available on the Senergy™ web site www.senergy.cc.

FIELD CUT DOOR INSTALLATION GUIDE

<p>STEP #1</p> <p>BUILDER NOTE: FIELD CUT OF PANEL CORE SHOULD BE AN 1/8" WIDER THAN REQUIRED ROUGH OPENING SIZE.</p>	<p>STEP #2</p> <p>BUILDER NOTE: FASTENERS MUST BE ATTACHED FROM INSIDE THE PANEL WITHIN 1/2" FROM THE END OF THE LONG LEG OF THE S-CLIP TO ALLOW FIELD 90 TO BE ATTACHED.</p>	<p>STEP #3</p> <p>BUILDER NOTE: FASTENERS MUST BE ATTACHED FROM INSIDE THE PANEL WITHIN 1/2" FROM THE END OF THE LONG LEG OF THE S-CLIP TO ALLOW FIELD 90 TO BE ATTACHED.</p> <p>ATTACH S-CLIP TO CORE @ BOTH SIDES OF OPENING</p>
<p>STEP #4</p> <p>BUILDER NOTE: JOINT OF FIELD 90 MUST BE OFFSET FROM JOINT IN PANEL</p> <p>1/4" - #14 X 3/4" SELF DRILLING FASTENERS 1'-0" O.C.</p> <p>BUILDER NOTE: FIELD 90 TO BE SLIT AND BENT WITH MIN. 12" EXTENDING FROM EITHER CORNER.</p>	<p>STEP #5</p> <p>BUILDER NOTE: FASTENERS IN FIELD 90 @ TOP OF DOOR MUST BE ATTACHED HIGH ENOUGH ON FIELD 90 TO ALLOW ROOM FOR WD STUD TO BE ATTACHED.</p> <p>ATTACH WD STUD TO FIELD 90 @ TOP OF DOOR</p>	<p>STEP #6</p> <p>ATTACH DOOR SUPPLIED BY OTHERS</p>

FIELD CUT WINDOW INSTALLATION GUIDE

STEP #1

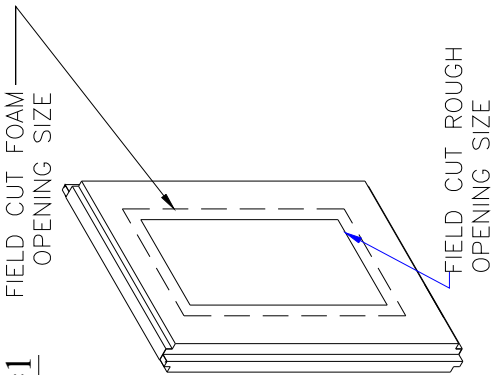

BUILDER NOTE:

FIELD CUT OF PANEL CORE SHOULD BE AN 1/8" WIDER THAN REQUIRED ROUGH OPENING SIZE.

STEP #2

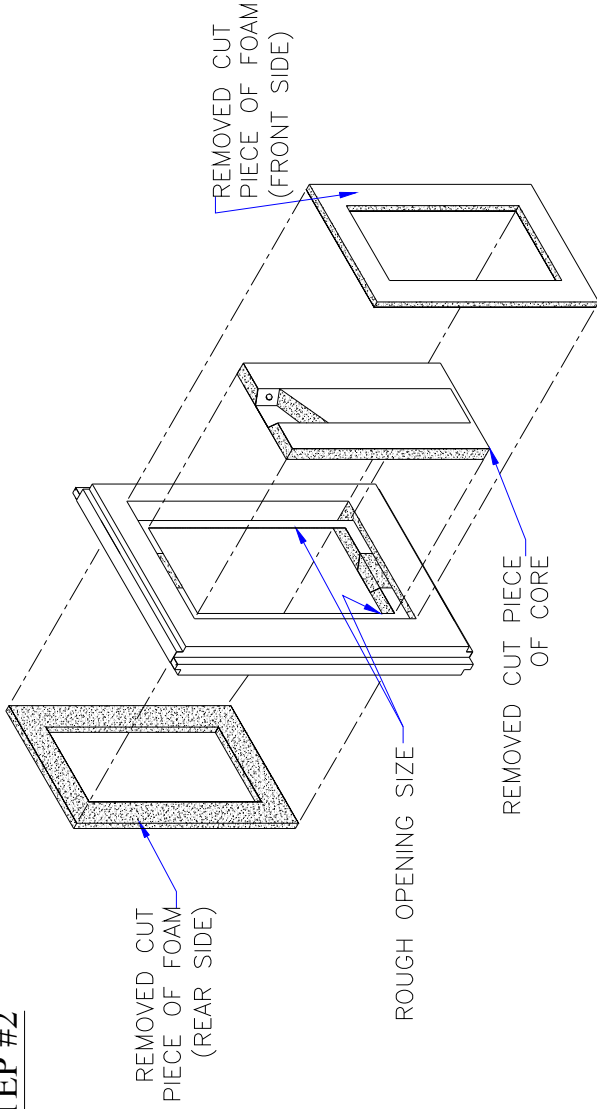

STEP #3

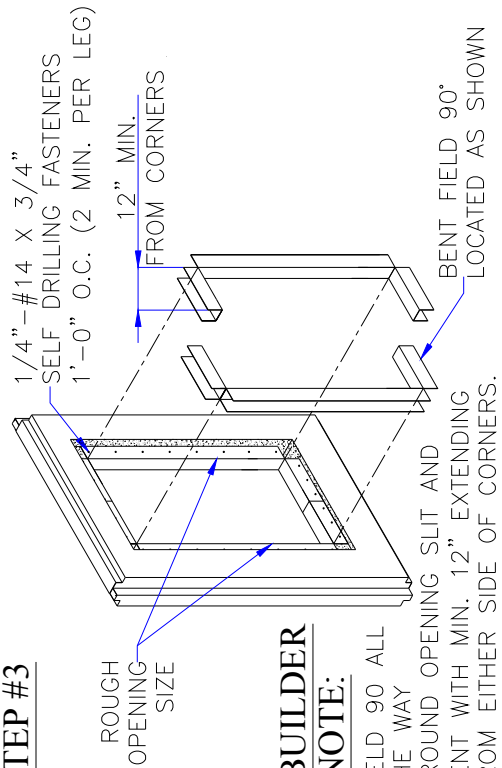

BUILDER NOTE:

FIELD 90 ALL THE WAY AROUND OPENING SLIT AND BENT WITH MIN. 12" EXTENDING FROM EITHER SIDE OF CORNERS.

STEP #4

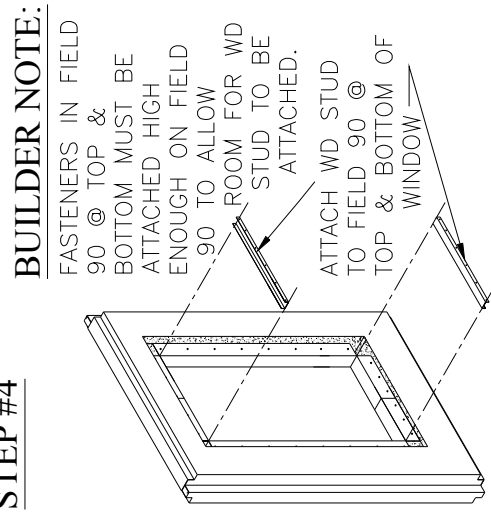

STEP #5

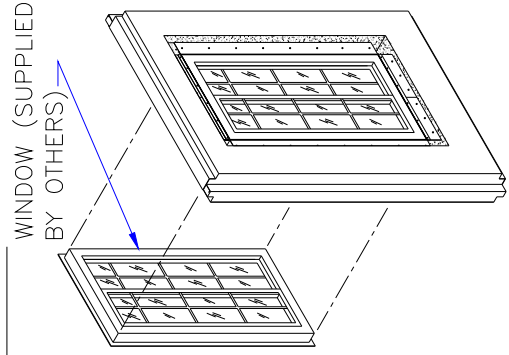

Sealing and Damp Proofing

Prior to backfilling, apply a waterproof sealer. A local coating applicator can advise on the types and installation of suitable sealing materials.

Wiring and Plumbing Installation

KORETECK® panels are designed to simplify the installation of chases for wiring and plumbing. There are no restrictions on the number or size of channels that can be cut into the face of the panels. The structural integrity of the panel is not compromised by the removal of small sections of foam for wiring or small box installation.

Typically the chases are cut using a hot knife or a router. Wiring can be pushed into the raceways; outlet and switch boxes can be cut into the foam similarly. The boxes are secured to the steel core using self-drilling screws.

The majority of plumbing is run in interior walls where insulation is less critical. However, should it be necessary to run plumbing in the exterior wall, the foam insulation can be removed to accommodate the piping.

FINISHING

Exterior Finishing

The **KORETECK®** system is designed to accept any type of exterior finishing. The walls can be finished with any hard or stucco finish system. **KORETECK®** panels are “stucco ready” reducing the wall preparation time, and therefore the installation cost, making stucco & acrylic finishes cost competitive with the more traditional finishes. The lack of a cavity in the **KORETECK®** system reduces the possibility of mold growth within the wall, a major issue with framed construction.

Important note:

Acrylic finishes when applied to the KORETECK® panel are not classed as an EIFS assembly. Therefore KORETECK is not subject to the same insurance restrictions that stud framed walls coated with EIFS are. Consult your local Senergy™ coatings representative to provide you correct installation details and answer questions on coating application.

Foam fillers are necessary at certain locations after panels have been stood. These areas include the exterior base and top track face, exterior stack joint face, and exterior corner connections. Utilize either foam fillers (by others) or foam dunnage sent with your order. When installing windows and doors, some exterior infill may be necessary based on the type of finish being applied to the panel.

Interior Finishing

Fire regulations require EPS foam to be covered to protect personnel during a fire. Drywall (1/2” thick) is a cost effective covering in most cases. FRP is also used in high moisture environments.

General Information:

Load Bearing Buildings

When KORETECK® panels are used for load bearing applications engineering on the building is the responsibility of an approved local structural engineer.

KORETECK® will supply the builder/engineer with detailed job specific panel location drawings for approval.

Load Bearing Panel Installation

Installation of load bearing panels follows the same fastening sequence. In lieu of fastening panel-to-structure, fasten panel to wood or metal header, to which you fasten temporary braces.



These braces must remain in place until roof trusses are on and roof sheeting (OSB or decking that is transferring load from roof to wall) is in place. Top track, similar to base track, must be installed on top stud of panels prior to nailer plate and truss installation.

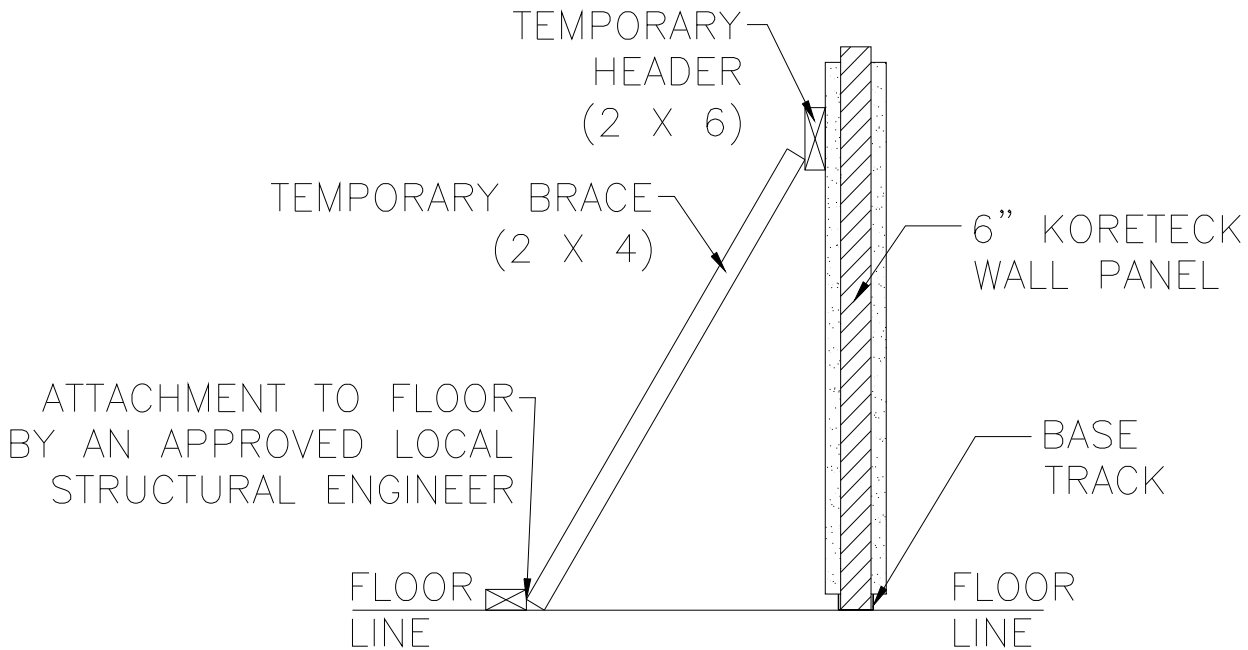

TEMPORARY BRACING LOAD BEARING WALLS

Copies of Test Data

Copies of fire, structural and acoustical approvals are available on request.

Appendix 1

Fastener Usage Chart

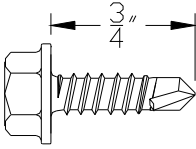
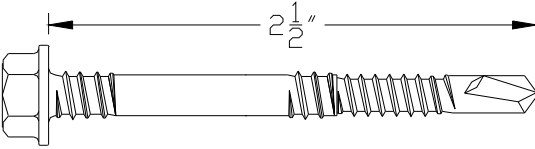
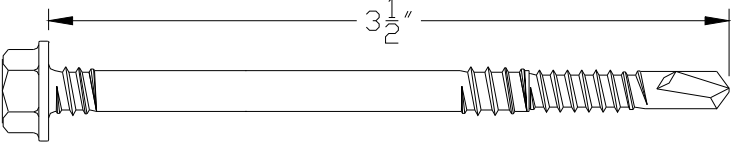
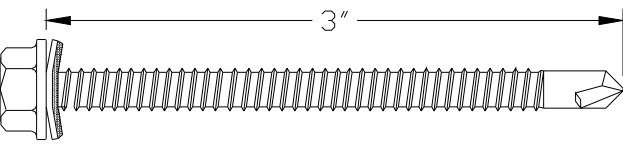
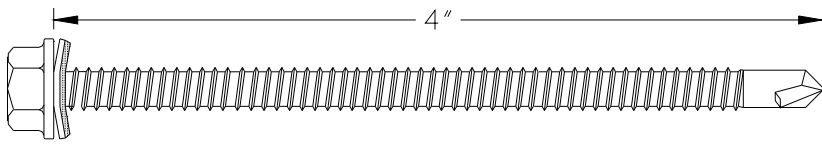
415		
	<p>1/4"-14 X 3/4" SELF DRILLING FASTENER 3/8" HEX HEAD W/O WASHER</p>	<p>PANEL TO PANEL CONNECTION PANEL TO BASE TRACK PANEL TO ZEE TRACK @ STACK JOINT PANEL CORNER CONNECTION</p>
405		
	<p>1/4"-14 #12-14 X 2 1/2" STICH THREAD SDF 3/8" HEX HEAD W/O WASHER</p>	<p>6" PANEL TO STRUCTURE CONNECTION</p>
410		
	<p>1/4"-14 #12-14 X 3 1/2" STICH THREAD SDF 3/8" HEX HEAD W/O WASHER</p>	<p>8" PANEL TO STRUCTURE CONNECTION</p>
097519		
	<p>1/4"-14 X 3" SELF DRILLING FASTENER 3/8" HEX HEAD W/METAL BACKED WASHER PAINTED TO MATCH TRIM COLOR PROVIDED BY BMC (NOT BY KORETECK)</p>	<p>GABLE TRIM WALL ADAPTER TO 6" PANEL EAVE CLOSURE TO 6" PANEL MISC. TRIM ATTACHMENT TO 6" PANEL</p>
097520		
	<p>1/4"-14 X 4" SELF DRILLING FASTENER 3/8" HEX HEAD W/METAL BACKED WASHER PAINTED TO MATCH TRIM COLOR PROVIDED BY BMC (NOT BY KORETECK)</p>	<p>GABLE TRIM WALL ADAPTER TO 8" PANEL EAVE CLOSURE TO 8" PANEL MISC. TRIM ATTACHMENT TO 8" PANEL</p>

SUPPORT

*For both wall and roof applications consult the provided load tables to make sure the panels are able to carry the wind and snow (live) loads. If you are unsure, consult you local **KORETECK®** distributor.*

Additional Information contact KORETECK™

Telephone: 1-866-877-8335

Fax: (540) 248 1173

E-mail: info@koreteck.com

Web Site Links

www.koreteck.com

www.butlermfg.com

www.mybuildernet.com

www.senergy.cc